

iglidur® Z | 產品範圍

法蘭軸承 (型號 F)

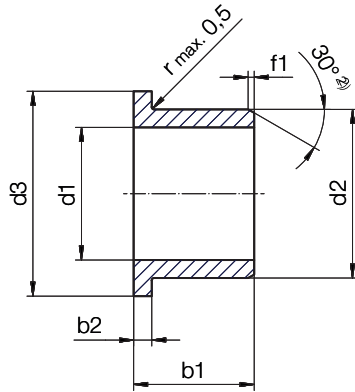

²⁾ 厚度 < 1 mm : 導角 = 20°

倒角和 d1 的關係

d1 [mm]:	Ø 1-6	Ø 6-12	Ø 12-30	Ø > 30
f [mm]:	0.3	0.5	0.8	1.2

尺寸 [mm]

d1	d1- 公差 ³⁾	d2	d3	b1	b2	產品型號
			d13	h13	-0.14	
4.0		5.5	9.5	4.0	0.75	ZFM-0405-04
5.0	+0.010	7.0	11.0	5.0	1.0	ZFM-0507-05
6.0	+0.058	8.0	12.0	4.0	1.0	ZFM-0608-04
6.0		8.0	12.0	8.0	1.0	ZFM-0608-08
8.0		10.0	15.0	5.5	1.0	ZFM-0810-05
8.0		10.0	15.0	7.5	1.0	ZFM-0810-07
8.0		10.0	15.0	9.0	1.0	ZFM-0810-09
9.0		11.0	17.0	20.0	0.5	ZFM-091117-20
10.0		12.0	18.0	5.0	1.0	ZFM-1012-05
10.0	+0.013	12.0	18.0	7.0	1.0	ZFM-1012-07
10.0	+0.071	12.0	18.0	9.0	1.0	ZFM-1012-09
10.0		12.0	18.0	12.0	1.0	ZFM-1012-12
10.0		12.0	18.0	15.0	1.0	ZFM-1012-15
10.0		12.0	18.0	17.0	1.0	ZFM-1012-17
10.0		13.0	15.0	5.5	1.5	ZFM-101315-05
12.0		14.0	20.0	7.0	1.0	ZFM-1214-07
12.0		14.0	20.0	9.0	1.0	ZFM-1214-09
12.0		14.0	20.0	12.0	1.0	ZFM-1214-12
12.0		14.0	20.0	17.0	1.0	ZFM-1214-17
12.0		14.0	20.0	20.0	1.0	ZFM-1214-20
14.0		16.0	22.0	12.0	1.0	ZFM-1416-12
14.0	+0.016	16.0	22.0	17.0	1.0	ZFM-1416-17
15.0	+0.086	17.0	23.0	9.0	1.0	ZFM-1517-09
15.0		17.0	23.0	11.0	1.0	ZFM-1517-11
15.0		17.0	23.0	12.0	1.0	ZFM-1517-12
15.0		17.0	23.0	15.0	1.0	ZFM-1517-15
15.0		17.0	23.0	17.0	1.0	ZFM-1517-17
15.0		17.0	23.0	23.0	1.0	ZFM-151723-23

³⁾ 按壓組裝後 測試方法 ▶ 頁碼 57

產品型號

類型 尺寸 [mm]

Z F M -04 05-04

iglidur® 材質	型號 F	公制	內徑 - Ø d1	外徑 - Ø d2	長度 b1
-------------	------	----	-----------	-----------	-------

尺寸符合 ISO 3547-1 標準
且提供特殊尺寸

也可選用英制尺寸
▶ 見頁碼 1444

d1	d1- 公差 ³⁾	d2	d3	b1	b2	產品型號
			d13	h13	-0.14	
16.0		18.0	24.0	12.0	1.0	ZFM-1618-12
16.0		18.0	24.0	17.0	1.0	ZFM-1618-17
18.0	+0.016	20.0	26.0	4.0	1.0	ZFM-1820-04
18.0	+0.086	20.0	26.0	12.0	1.0	ZFM-1820-12
18.0		20.0	26.0	17.0	1.0	ZFM-1820-17
18.0		20.0	26.0	22.0	1.0	ZFM-1820-22
20.0		22.0	30.0	21.0	1.0	ZFM-2022-21
20.0		23.0	30.0	11.5	1.5	ZFM-2023-11
20.0		23.0	30.0	16.5	1.5	ZFM-2023-16
20.0		23.0	30.0	21.5	1.5	ZFM-2023-21
20.0		23.0	30.0	15.5	1.5	ZFM-2023-155
20.0		23.0	30.0	16.5	1.5	ZFM-2023-16
20.0		23.0	30.0	21.5	1.5	ZFM-2023-21
20.0		23.0	30.0	31.5	1.5	ZFM-2023-31
25.0	+0.020	28.0	35.0	11.5	1.5	ZFM-2528-11
25.0	+0.104	28.0	35.0	16.5	1.5	ZFM-2528-16
25.0		28.0	35.0	21.5	1.5	ZFM-2528-21
25.0		28.0	35.0	31.5	1.5	ZFM-2528-31
30.0		34.0	42.0	13.0	2.0	ZFM-3034-13
30.0		34.0	42.0	16.0	2.0	ZFM-3034-16
30.0		34.0	42.0	20.0	2.0	ZFM-3034-20
30.0		34.0	42.0	26.0	2.0	ZFM-3034-26
30.0		34.0	42.0	37.0	2.0	ZFM-3034-37
35.0		39.0	47.0	16.0	2.0	ZFM-3539-16
35.0		39.0	47.0	26.0	2.0	ZFM-3539-26
40.0	+0.025	44.0	52.0	20.0	2.0	ZFM-4044-20
40.0	+0.125	44.0	52.0	30.0	2.0	ZFM-4044-30
40.0		44.0	52.0	40.0	2.0	ZFM-4044-40

iglidur® Z | 產品範圍

法蘭軸承 (型號 F)

尺寸 [mm]

d1	d1- 公差 ³⁾	d2	d3 d13	b1 h13	b2 -0.14	產品型號
45.0	+0.025	50.0	58.0	50.0	2.0	ZFM-4550-50
50.0		55.0	63.0	20.0	2.0	ZFM-5055-20
50.0	+0.125	55.0	63.0	50.0	2.0	ZFM-5055-50

d1	d1- 公差 ³⁾	d2	d3 d13	b1 h13	b2 -0.14	產品型號
60.0	+0.030	65.0	73.0	50.0	2.5	ZFM-6065-50
75.0		80.0	88.0	50.0	2.5	ZFM-7580-50
75.0	+0.150	80.0	94.0	65.0	3.0	ZFM-758094-65

³⁾ 按壓組裝後 測試方法 ► 頁碼 57



沒有找到您要的尺寸？

您是否需要其他長度、尺寸或公差？您在尋找一個特殊的設計或取代您應用的其他解決方案？請與我們聯絡。易格斯傾聽您的需求，並在短時間內迅速為您提供解決方案。



更多尺寸可現貨供應

超過 300 個尺寸可供選擇。線上搜尋您所需的軸承。

► www.igus.com.tw/iglidur-specialbearings